



- Corporate** Slackwire - Meet & Greet - Drum & Whistle - Roving - Routines
- Cabaret** Slackwire - Meet & Greet - Drum & Whistle - Wild Creature - Routines
- Festivals** Slackwire - Meet & Greet – Roving - Routines
- Theatre** Slackwire - Drum & Whistle - Wild Creature - Train of Thoughts - Meet & Greet - Routines
- Circus** Slackwire – Routines - Drum & Whistle - Meet & Greet
- Schools** Train of Thoughts – Workshops - Artist in residence project - The Greatest Earth On Show.  
Details - see schools on website
- Parades** The Itchy Feet Pep Band - Novelty Bike
- Holiday Events** Slackwire – Drum & Whistle – Wobbly Bike – Workshops Meet & Greet - Roving
- Family Events** Slackwire - Meet & Greet - Drum & Whistle - Train of Thoughts - Wobbly Bike – Workshops - Roving

## Peter Gray - Circus Character Comedy Cabaret

Details of performances styles and options included in folder.



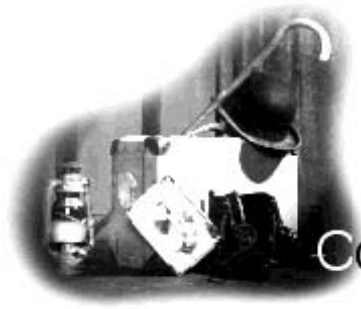

## Corporate Performances

Help solve the entertainment needs of an event with quality rather than quantity. The enclosed material will help you choose from the variety of performances and characters I have to offer. All acts are presented with universal appeal via music & vision. No language barrier! My aim is to help make the entertainment at your event memorable and unique.

### **PACKAGE DEALS AVAILABLE!**

For the course of an event you might decide to book - Meet & Greet + Drum & Whistle + Slackwire Act. Packages save money and organization at the same time as giving the audience more from less.

**Slackwire** Performance length variable. Maximum length 30min.  
One fee applies for act options 1, 2 or 3. (See slackwire description page)

**Slackwire - performance art** Maximum length 60min.  
Suitable for a modern environment. e.g. Art exhibition/gallery or museum.  
This is not an act with a fixed audience in mind. It is improvisational, designed for a passing audience. The experience would be like watching a live exhibit at a zoo.

**The Wild Creature - performance art** Maximum length 60min.  
Balancing skills on a jungle vine. e.g. Zoo or rainforest (improvisational - same style as above)

**Drum & Whistle** Performance length 15min.  
A comical mixture of clever ball juggling, and audience involvement.

**Meet & Greet or Roving** Maximum length 120min. (2x60min sessions)  
A choice of character to 'break the ice' while adding a touch of class.

**Routines** Performance length variable. Maximum length 15min.  
A selection of short stage routines designed for concert programmes.  
Fee is variable depending upon the character, style, or length of act.





# Character Description



**Angelo**

Angelo is the most humorous of my characters, always creating the impression he's in charge, but it's really all bravado! Angelo performs only in roles that show off his splendour. He is proud, full of pose, and an attention seeker. We cannot afford to take him too seriously!



**Deip**

Of my characters Deip is the most versatile, taking circus skills to a higher level. During a performance, the creative space in which Deip moves is greater covering a wider spectrum of music, movement, mood and meaning. The name "Deip" is another way of saying "deep" deriving from his ability to reach depths of emotion. Unlike the other characters that display more extreme features, Deip is subtle, refined, and not as confronting to his audience.



**Nelligan**

Nelligan is an old man who was once an entertainer. Nelligan is friendly to everyone who passes, and simply wants to share the skills of his past. There's a loneliness that comes forth in his effort to say, "Excuse me, but once I used to be" Nelligan can be very gentle, but also cranky. If people show kindness, he might play the spoons. If they are rude to him, he turns his back and hobbles away.



**Pedro**

Pedro with many touches of eccentricity stretches the boundaries of formality. Running on nervous energy, he is smooth and slick, fussy and fickle! Pedro sets out to ease and please, but bitchy bursts interrupt his finest intentions. In the confusion comical moments appear, and much to Pedro's frustration one problem is solved while another one is created.





## Highlights



Performed at the Sensational Adelaide International Police Tattoo as Angelo the Drum Major with The Itchy Feet Pep Band. The Tattoo featured Brass and Pipe Bands from Singapore, United Kingdom, Canada and Australia. Our act proved to be an outstanding success performing to five thousand people each night. The show was televised by Australia's Channel 7 for National and International viewing.

Performed in Casino Promotion's production of 'Aqueous' Circus of Wonders entertaining audiences from all over the world at the Reef Hotel Casino - Cairns Australia

Played the white faced clown in the stage musical 'Barnum' presented by Edgley International, The Australian Elizabethan Theatre Trust and the Adelaide Festival Centre Trust.

Performed at Brisbane's World Expo as the only solo artist engaged for the entire six months.

Created an 80 minute show focusing on our environment entitled 'The Greatest Earth On Show'. This involved training and directing 300 school children aged between 5 and 11 over a 6-week period in the areas of circus and theatre.

Appeared in a variety show with my performance 'The Wire Swing' at Her Majesty's Theatre, Melbourne Australia.

Performed comical routines with the Melbourne Philharmonic Orchestra presenting amongst many other things a spoon solo!

Performed as Drum Major, Choreographer, and Artistic Consultant with 'The Itchy Feet Pep Band' The Band originated from World Expo'88, and since then has traveled extensively including representing Australia in Hong Kong for the Chinese New Year Parade.

Toured Australia for the International Year of the Child presenting performances for schools and community groups.

**Performed a solo show at the Victorian Arts Centre, Melbourne Australia.**





# Slackwire Act

**The following options are effective in a variety of ways.** (Not only circus theme events)

**Option 1 (As outlined on the website)** Nelligan starts the show. First he mingles in the audience showing an old photograph of his younger days. The performance officially begins with the introduction of music directing Nelligan's memories to the slackwire. After wobbling around on the wire various feats are achieved. To the audience's surprise, Nelligan doesn't stay old for long. He actually changes clothes while balanced on the wire transporting him and the audience back to the days when he was a young energetic performer. This act features a mix of difficult balancing skills, and hilarious moments with help from audience members.

## **Option 2**

Deip performs the entire act. The performance includes very much the same skills and format as option one except it does not have the old man content. Changing clothes on the wire is still featured as well as all the comedy aspects including participation from members of the audience. The style of presentation is different to option one, more suiting Deip's character. From beginning to end this act moves at a sprightly pace.

## **Option 3**

This act features a new character (not yet shown on the website) created to match the aesthetic look of the new slackwire apparatus. All the skills featured are the same as option one and two, except that it has a futuristic feel in a similar vein to the famous French/Canadian circus 'Cirque du Soleil.' It also includes a serve of comedy with members of the audience.

## **Option 4 (performance art)**

The new character together with the new slackwire apparatus has the ability to fit in to a modern environment. E.g.: Art gallery, exhibition, or museum. This performance is not structured like a normal stage presentation.

## **Option 5 (performance art) The 'Wild Creature'**

(See character page on website) is presented in the same format as option 4 except there is no fancy slackwire apparatus. Balancing skills are featured on an old thick rope made to look like a jungle vine. Because there is no self-supporting apparatus, special arrangements would need to be made to secure the 'jungle vine'. This option is best presented in the environment of a zoo or rain forest, and would be viewed as an exhibit.





## Meet & Greet

Information technology draws the world nearer, but the distance between people in fact grows further apart. There is a lot of meeting going on, but not a lot of greeting!

Amid the steele grids we create, give your event a human face. Why not invite Angelo, Pedro, or Nelligan to help personalise proceedings.

The following 3 characters in their own particular manner offer 3 different ways for guests to feel welcome at your event. Upon meeting them not only will your guests be entertained, they will feel an immediate sense of occasion. Angelo, Pedro, and Nelligan will break the ice while at the same time add that necessary touch of class!



Pedro

**Pedro** flamboyantly dressed, welcomes guests as they arrive, and assists by ushering them to their seats. While guests wait for official proceedings to begin, they are spontaneously entertained by Pedro's antics. During the action, red carpet treatment is offered to a privileged few, while ignoring others with comical consequences! Pedro with a flare and flourish stylishly struts amongst the guests creating heavenly havoc!



Angelo

**Angelo** provides the same service as Pedro, but in an ordered and regimented manner. No hands in pockets and standing up straight are automatically expected. Looking splendid and like a million dollars, Angelo means business. Comedy is created by Angelo's preoccupation to detail, and it's not long before guests realise they cannot take themselves too seriously.



Nelligan

**Nelligan the Butler** formerly dressed, ambles about the event fully intending to welcome the guests, but there are times he gets absent-mindedly sidetracked. Instead of Nelligan assisting the guests, they might need to assist him! Even though Nelligan performs the same duties as Pedro and Angelo, his character is vastly the opposite. Rather than be in your face Nelligan chooses to weave his way amongst the guests blending and attaching himself while at the same time charming all those he meets. (Nelligan the Butler is not yet featured on the website).

In the process of meeting and greeting all 3 characters don't speak, but through close eye contact, body and face expression, more is accomplished than words could ever achieve!





Drum & Whistle is successful where ever it is performed. This act through the universal language of laughter has brought together a variety of audiences from a variety of backgrounds. This routine has been presented very effectively in all sorts of situations, including Corporate, Cabaret, Festivals, Schools, and Prisons! It doesn't matter what type of audience, this act is guaranteed to have the audience rolling in the aisles.

*"I was always impressed by the tasteful way in which Peter was able to involve the audience participants without stripping them of their dignity."*  
Vincent Lopes - Director Rembrandts Theatre Restaurant

Both of the following options begin with a music intro. Character appears and gathers approx 4 audience members. Progresses with no music for about 10 minutes, then finishes with a music outro. Audience members are returned to seats and character exits.

#### **Option 1** (as outlined on website)

Angelo in his commanding style invites members of the audience to be part of the performance. They are given percussive instruments, and are required to create sound effects while Angelo juggles. The routine builds from one ball to several, and along the way there are a lot of laughs, as Angelo expects nothing but the best from his orchestra! This act displays a mixture of clever ball juggling, and effective audience involvement.

#### **Option 2**

Nelligan also performs this act. The routine is the same, but in the style of an old man.

**Length of Act:** approx. 15 minutes

**Performance Space:** Minimum Width 5 metres Depth 4 metres Height 3 metres

**Props:** Drum, juggling balls, bag of percussive instruments (drumsticks, cymbals, sliding whistles, and tambourine)





**Featuring the character - Nelligan.  
When you choose Nelligan roving you have two options:**



Wherever old people are seen, Nelligan is comfortable. He loves to be part of the crowd, and if he feels up to it - the centre of attention! While Nelligan wanders, he becomes a grandpa to children, a digger to old folk, an old fart to youth, and an old entertainer to everyone!

Apart from Nelligan wanting to share a sandwich or carrot, he enjoys playing the spoons and balancing his walking stick. Most of all he takes pride in showing people his old photo of the time he was an entertainer.

**Nelligan's roving act began at Brisbane's World Expo 1988, and has been an outstanding success ever since.**

"Your old man character gave a touch of humanity to the street entertainment. The public were enthralled, and found the old man charming and challenging. My staff and I received many favourable comments from the general public"

**Barbara Absolon - Walkways Producer - Brisbane Australia's World Expo**

**Peter Gray - Circus Character Comedy Cabaret**



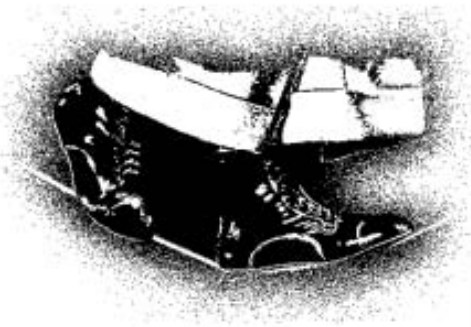

## Style & Skills



Content, character and skills can be designed to suit your event

Performances include comedy, various forms of juggling, intricate balancing, dance, and audience participation.

The characters do not speak, but utilise the combination of body language, skill and music to visually entertain.

Performances from the repertoire are choreographed with timing playing a major part in the presentation.

*Slackwire*  
*Rolling Globe*  
*Ribbon Twirling*  
*Playing Spoons*  
*Character*  
*Writing*  
*Makeup*  
*Hoops*



*Juggling*  
*Balancing Objects*  
*Choreography*  
*Rola Bola*  
*Directing*  
*Unicycle*  
*Roller*  
*Dance*





These are a collection of short routines additional to those acts already spotlighted. Unlike the other acts these short routines if presented by them selves do not stand-alone. They are best seen as an item housed in a production style of show featuring other performers. e.g.: A Cabaret or Variety show.

**The skills featured in these routines do not include the slackwire.** One fee applies no matter the character, style, or length of act. Length of routines varies from 3 min. to 10min.

<b>Classical Guitarist</b>	Comedy with music stand and guitar
<b>Spoonastics</b>	Comedy spoon playing solo
<b>Audience Juggle</b>	Comedy with two members of the audience juggling objects
<b>At The Beach</b>	Comedy balancing, using mini surfboard, deckchair and beach ball.
<b>Ticket Lost</b>	Serious glimpse of a lost life from birth to death.
<b>Global Dawn</b>	A celebration of rhythm, ribbons and rings while balanced on the rolling globe
<b>Petrina Grayoski</b>	Ballet at it's worst
<b>Busker At Dusk</b>	Faded talents of an old street entertainer are revitalised
<b>The Artist</b>	A lady in the audience is asked to pose at the hand of a pedantic artist with comical results.
<b>The Picnic</b>	Comedy with bees, ants & eggs





# Early Days

Overnight something bright appeared on the rusty corrugated iron fence. It was a sight that always made my heart beat with excitement, and it also made two weeks seem a very long time. New and fresh in the morning sun was a poster announcing the arrival of Wirth's Circus by train.

For the rest of the afternoon and the days to follow I could hardly wait. Not much schoolwork was done. In bed at night I'd hear the distant whistle of a train passing by our town and I'd wonder what it would be like to go on a journey traveling and performing.

Finally the big day came! I sat impatiently at my desk waiting for the playtime bell to ring and when it did, I ran with other children down to the school fence to watch the parade of colourful wagons roll past. At lunch time I'd sneak up to the oval just in time to see the huge tent rise above the trees, and on the way home I'd stop to catch a glimpse of trapeze artists mending their nets and performers practicing. It took a little longer that day to get home, but mum and dad somehow knew where I was. At dinner time I chatted all about what I had seen, and was about to see, and within moments it seemed we were driving down the hill towards hundreds of tiny lights glittering in the night sky. Soon the car doors slammed, and we took our seats on the splintery boards covering ourselves with blankets. After staring at all the equipment littering the canvas roof, the lights finally went down, and the band struck up introducing the most spectacular things beyond what I could ever imagine!

That night was a special experience I shall never forget, but the next morning I felt the opposite. On the way back to school once more, I noticed the oval was bare. All that was left were patches of sawdust and smouldering heaps of rubbish. I dawdled to school and looked across from assembly at the circus poster which was now tattered and flapping in the breeze. I stood blank faced thinking how lucky the people in the next town were. Just as I was starting to feel the day was going to be dull and drab, an idea flashed into my mind! Instead of waiting for the next show to hit town, why not invent my own. At that point I couldn't wait to get home.

## **Backyard beginnings**

Fascination of circus began for me at the age of nine, not under a big top, but under a Hills Hoist (Australian clothesline invention). As I played in the backyard, lemons became the juggling balls, and a rope between trees became the tightrope. In those early years I couldn't tighten the rope, so as a result I became accustomed to the precarious motion of a loose rope. Step by step I started to feel at home not on a tightwire, but a slackwire. Later this proved to be a bonus, because in the world of the Performing Arts a slackwire act is rarely seen.

## **A unique mix of theatre and circus**

Soon after, other skills developed, along with a keen interest in theatre. There was much to learn, yet none of the groundwork came from formalised training or specialised colleges, which partly explains my different style. During this time, ways were discovered to make ordinary things look interesting, and with my love of music and makeup, imaginary characters came to life. As my career developed I realised that the key to holding the audience's interest was not only found in clever human feats, but in character communication. Hence a unique mix of theatre and circus emerged





## References & Press



**Nina Randall**  
**Director Casino**  
**Promotions**

Peter Gray was recently employed by Casino Promotions in the production of "Aqueous - Circus of Wonders", staged at The Reef Hotel Casino, Cairns, Queensland, for a sell out, and extended eight-month season.

During this time, Peter displayed a charismatic charm in the various humorous characters he portrayed through "mime" in our show. With his dancy moves, intricate balance and agility on the slackwire, he dazzled and entertained audiences from all over the world.

We found Peter to be an exceptional and polished performer. He was punctual, mature, honest loyal, committed to his work, and reliable. He had excellent communication and organization skills, a great sense of humour, positive attitude, and likeable personality.

We have no hesitation to recommend Peter Gray for any job that requires a true professional at his craft, especially as a slackwire artist.

Peter Gray has worked closely with us over the last three years. He is seen at his best when performing his mime and clown routines. I recently saw Peter performing in a benefit concert, and he literally brought the house down.



**Jim Cranfield - Tour Manager**

Peter's characterizations enthralled the capacity audiences that he drew to every Piazza performance. Whether as the little old man playing the spoons and balancing on a rolling board, his brilliant slackwire act or the wobbly bike routine, Peter captured the hearts of young and old alike.

I was particularly impressed by the presentation of Peter's skills, and the great attention to detail. Juggling, balancing, slackwire and audience participation, combined with his many other skills were presented in an extremely well choreographed, entertaining routine.

Apart from the total professionalism of Peter's work, he was pleasant to work with and able to adapt his shows to any type of situation which arose. I have no hesitation in recommending Peter Gray as an asset to any entertainment program requiring expertise and professionalism.



**David Hamilton**  
**Piazza Producer**



Peter is a talented, imaginative and creative performer who sets high standards for himself and those around him, and the result is always a successful show.

Unlike any other mime act, juggler or wirewalker, Peter offers a unique style of entertainment where his various characters and their situations are tastefully blended with his many circus skills. Peter combines the razzle-dazzle of the feat performed with the emotional tug of the mime story told.

Peter Gray is a thorough professional in every way, extremely talented, and very experienced in many forms of entertainment. His performances were extremely popular with our audiences, and were always punctuated with vigorous bursts of spontaneous laughter and applause.



**Mary-Clare Power  
Amphitheatre Producer**

Peter thank you for contributing so much to the success of World Expo, and for adding professionalism to the Entertainment Division.



**Vincent Lopes - Director**

Several of Peter's routines involve people he has selected from the audience, and I was always impressed by the tasteful way in which he was able to involve the participants without stripping them of their dignity.

Peter your willingness to become involved in projects dealing with different groups was fantastic. Each of your performances over the six-month period were wonderful, and certainly well received by our audiences. I'm well aware of the following you developed over the months, and it is a credit to such a professional to have maintained the enormous energy levels required. To have survived the full run is a feat in itself.



**Ric Birch  
Director of Entertainment**



**Barbara Absolon  
Walkways Producer**

Peter Gray is an accomplished and professional performer in the field of "silent entertainment".

His work is subtle and innovative while sustaining a charm that engages a variety of audiences.

I particularly admire the sensitivity of his mime, and the variety of roles that he has developed through his art.

It was my pleasure to work closely with Peter as he performed for several thousand people in the Sydney Myer Music Bowl sponsored by the Victorian Ministry for the Arts in association with channel 10 television broadcasting station.

In all of my dealings with Peter Gray, he has shown himself to be a responsible and professional performer.

**Press**

*"It is an extraordinary performance - the character and timing never faltering"*  
**Alan Attwood - Time Magazine Australia**

*"Funny in a human way"*  
**Alan Roberts - Adelaide Advertiser**

*"Eloquence without words from an endearing man"*  
**Hope Hewitt - Canberra Times**

*"Peter Gray emerges as a well practiced mime, balancing artist and juggler. Children and grown ups alike are seduced by Gray's gentle, but demanding approach."*  
**Jill Morris - Melbourne Age**

Peter your old man character gave a touch of humanity to the street entertainment.

The public were enthralled, and found the charming old man as he wandered challenged them to tricks and generally entertained.

My staff and I received many favourable comments from the general public.



**Betty Pounder  
Producer and Choreographer**





## Slackwire Introduction

Talk about a wire act, and most people think of a tightwire. They are generally not aware there is another wire act called the slackwire. Because one is tight and the other slack the two types of acts require completely different balance techniques. The tightwire is balanced from the hips up, and the slackwire from the hips down.

How it all came about with me was accidental. As a child, I imagined I was on a tightwire. That's what I'd seen in a circus, and that's what my imagination centered around. I didn't come from a circus family, so in my mind I knew no difference. For me the reason it became a slackwire, was that as a child I wasn't strong enough to tighten it! As I look back and think of what I have today, I'm glad that I tied a rope to a peppercorn tree and began to balance. When I fell, and felt like giving up, I'm so glad I picked myself up and continued to wobble around on what was to eventually become a slackwire act!

Audiences across the world rarely see the balancing skills of a slackwire act. Why? My theory is that a slackwire requires more time, practice and patience to get just to the stage of standing on it. In the same amount of time taken on a tightwire, the trainee would be already walking, and have commenced more difficult tasks. This is not to say that a tightwire is any less difficult, it's just that at the beginning stages of practicing the tightwire, the trainee experiences a quicker sense of achievement, and because of this, is more likely to go on to develop a tightwire act. In the long term if one is to succeed in either, both types of wire acts demand just as much time and patience to reach a high level of performance.

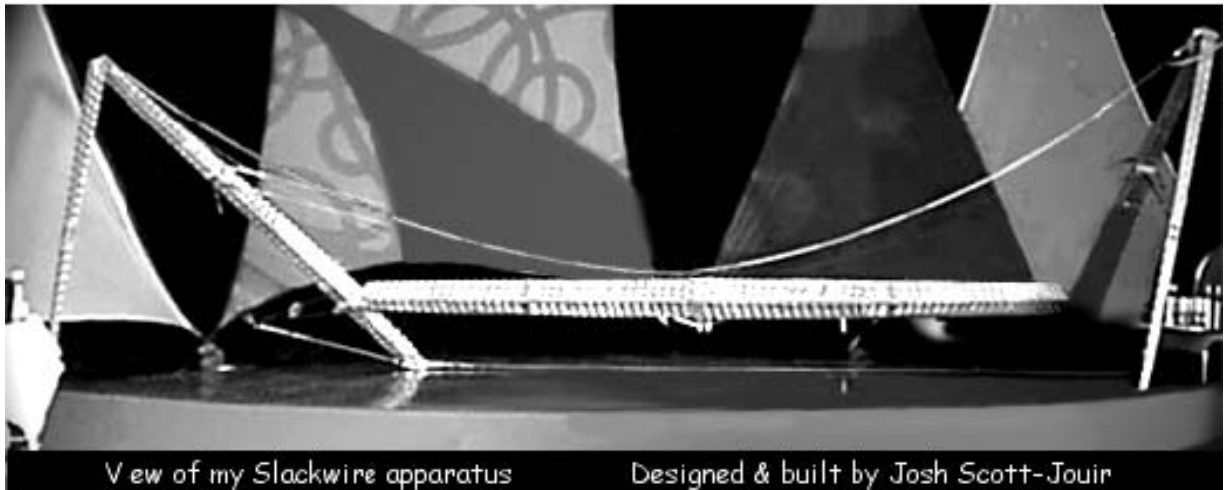

View of my Slackwire apparatus

Designed & built by Josh Scott-Jour





## Slackwire Details

### Practical Information

Duration Performance length is flexible - 30min. maximum

### Performance Space

Required minimum - **Width 7 metres - Depth 5 metres - Height 4 metres**

### Apparatus

Is a self-supporting, freestanding device?

Sits on 4 feet placed on small rubber mats. Leave's no marks.

It can be set up on any level surface E.g. Carpet, Polished Wood, Cement, or Lawn.

**Completely assembled, takes the space of 6.50 m x 4.50 m.**

**Completely dismantled, takes up the space of a car boot.**

### Set Up Options

**Option A (Ideal set up)** The apparatus already pre-set in performance space before audience arrive.

**Option B** Completely pre-set off stage area then carried into performance space. This process would require 2 Crew to put in place.

**Option C Apparatus** pre-set in 3 major parts off stage area.

This situation is when there is not enough storage room off stage to leave the apparatus completely set up. Just prior to the scheduled performance the 3 major parts of the apparatus are moved into position and connected in readiness.

To put the 3 parts in place, and speedy assembly it will require 2 Crew. Set up time - approx. 6 min.

### Option D

Apparatus assembled from scratch. (Set up time is approx. 45min) This involves fitting all the intricate parts together and the tensioning of the wires. It is important to have everything just right for safety. Assuming the performance space is not needed by anyone else, the apparatus, which is interesting to look at, can be set up by a character as a way of keeping the guest's curiosity alive! This idea may provide an entertaining backdrop as guest's wine and dine.

### Arrival Time

4hrs.minimum before audience arrives. Allows for unloading, parking, shifting & assembling gear, moving into dressing rooms, lighting & sound check etc. Does not include rehearsals.





## Slackwire Measurements

Drawing not to scale  
Self-supporting apparatus

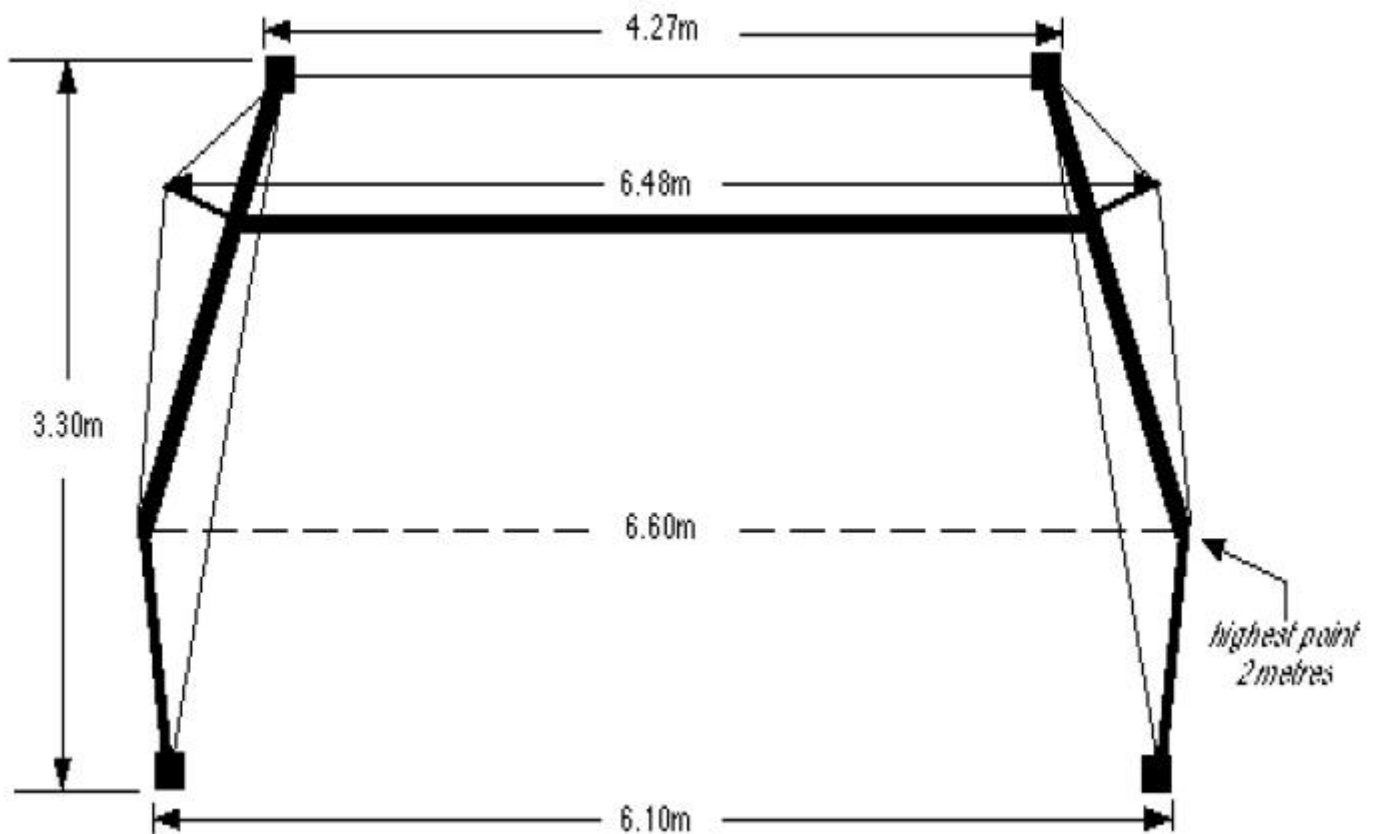



## Apparatus Plan View

Drawing not to scale

The small black squares represent the 4 rubber feet the apparatus rests on.  
 If the apparatus is to go on a portable stage, it is essential the stage structure is secure, the surface area is entirely level, and the width and depth is big enough to fit the 4 feet on.

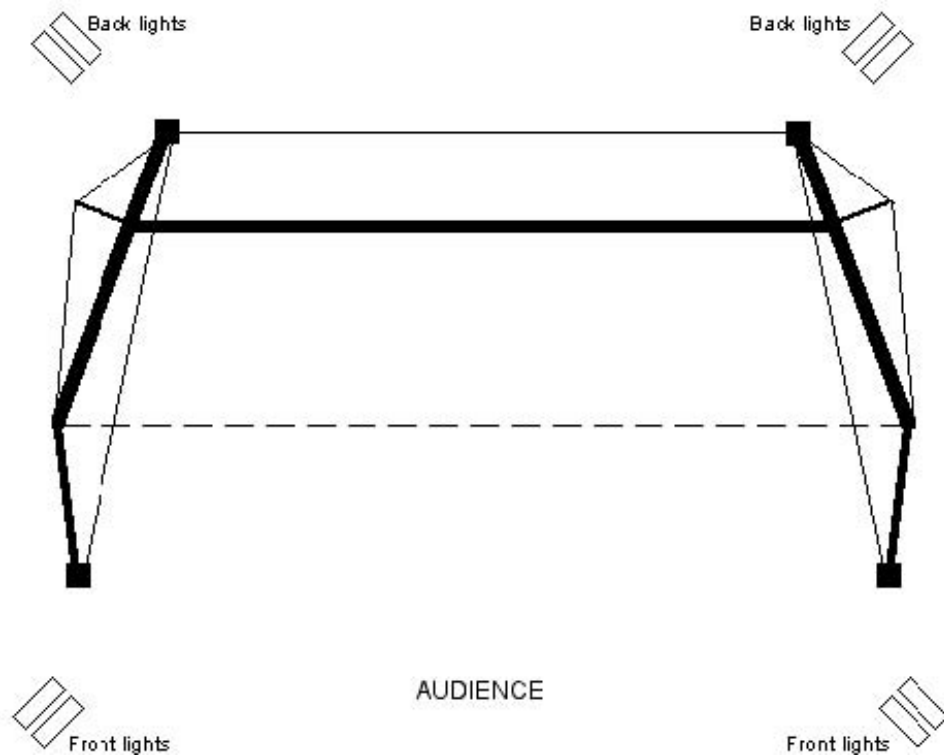

If lighting is to be used, lighting on diagram represents the direction of light from 4 angles.

The dotted line represents the wire walked on being the widest point of the apparatus = 6.60 metres.

Width of back feet = 4.27 metres = Width of front feet = 6.10 metres.  
 Depth from back feet to front feet = 3.30 metres.

Slackwire Act minimum performance space is:  
 Width 7.00 metres - Depth 5.50 metres - Height 3.50 metres

